

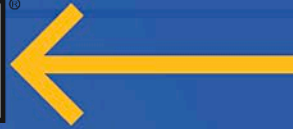

SPDM 1.3 and Beyond

Sep 2023

Chandra Nelogal
DMTS, Dell Technologies
Co-Chair, Storage Work Group, TCG



- The information in this presentation represents a snapshot of work in progress within the DMTF.
- This information is subject to change without notice. The standard specifications remain the normative reference for all information.
- For additional information, see the DMTF website.
- This information is a summary of the information that will appear in the specifications. See the specifications for further details.



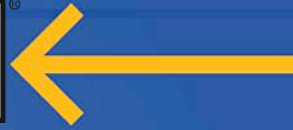

Component Threat Vectors

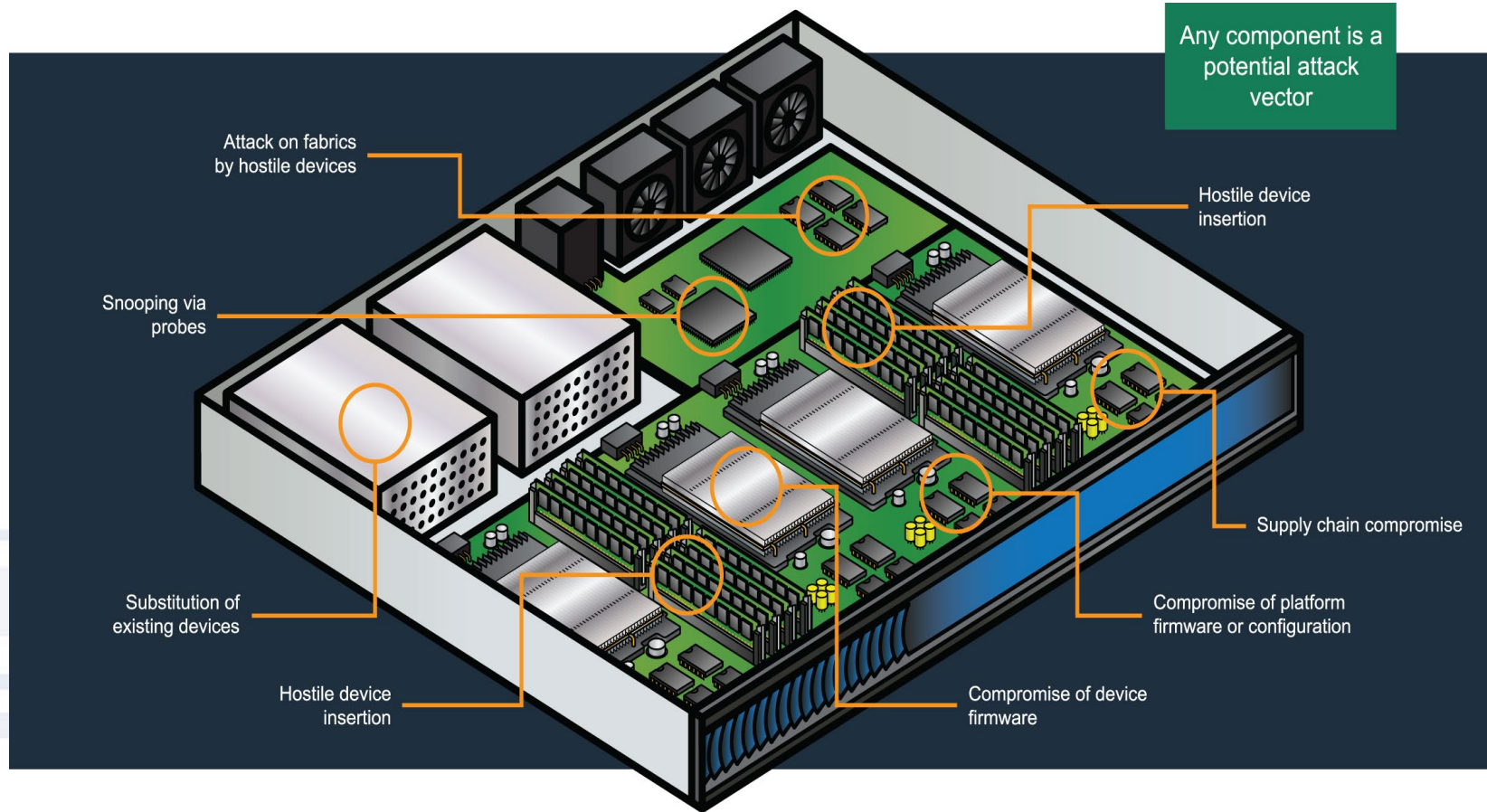

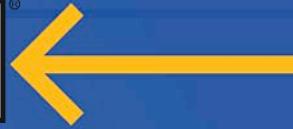

SPDM's Overall Goals

- All SPDM features fall into at least one of following main goals:
- **Device Attestation and Authentication**
 - The ability to attest various aspects of a device such as firmware integrity and device identity
- **Secure Communication over any Transport**
 - Provide the ability to secure communication of any data or management traffic over any transport
 - Work with industry partners to ensure data in-flight is secure for all parts of the infrastructure (e.g. storage, network fabrics, etc.)

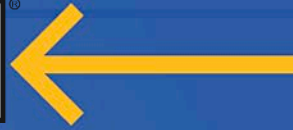

Alliance Partners and Adopters



OPEN
Compute Project



**TRUSTED
COMPUTING
GROUP**



SPDM Feature Summary (2023)

- Version 1.0:
 - Measurement Support
 - Device Attestation and Authentication
- Version 1.1:
 - Secure Session
 - Public Key Exchange
 - Symmetric Key Exchange
 - Mutual Authentication
- Version 1.2:
 - Supports installation of certificates
 - Allows for alias certificates derived from device certificates
 - Send and receive large SPDM messages (chunks)
 - Added SM2, SM3, SM4 algorithms to supported list
 - New OIDs added
 - Deprecated basic mutual authentication in CHALLENGE and CHALLENGE_AUTH

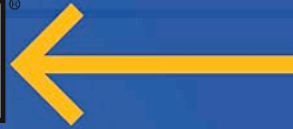

SPDM 1.3 Features

- Event Notification Mechanism
- Multi Key Support
- New Measurements
- Measurement Extension Log
- Structured Manifest format
- End Point Info



Event Mechanism

- Subscribed events
 - Interested Event Types
- All event notifications in a Secure Session
- Event Types could be extended by other standards bodies
- Can discovery supported event types and subscribe
- Notifications are ACK'd

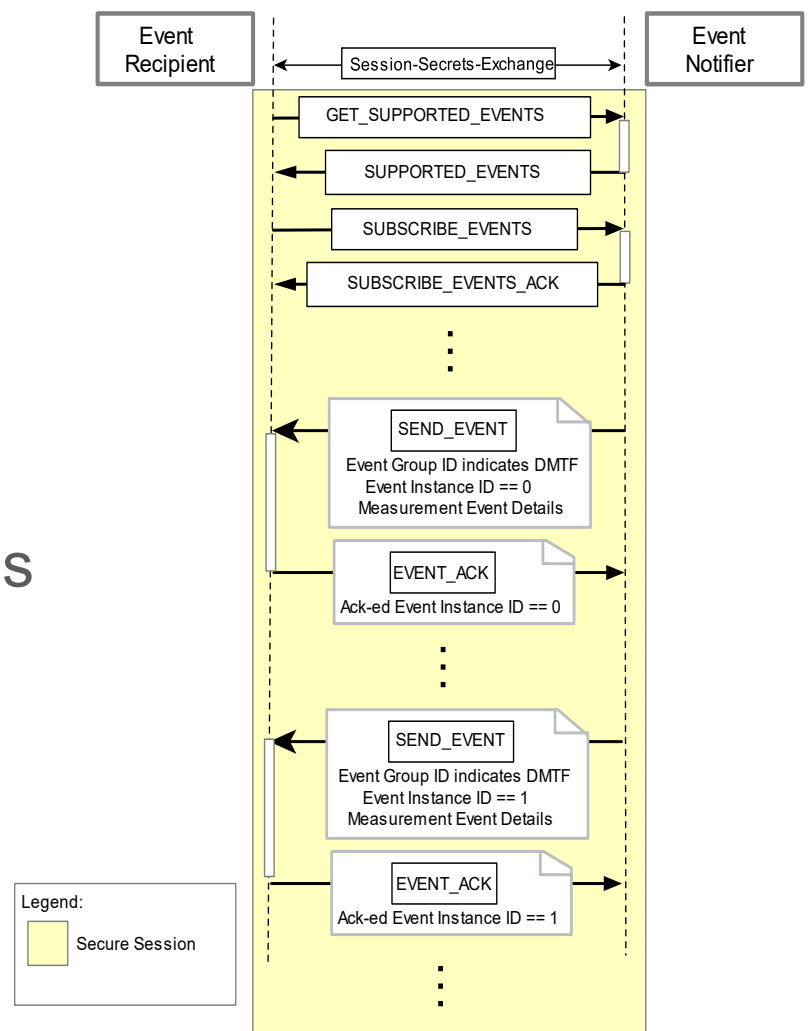



Multi Key Support

- Previous versions of SPDm only allowed one key pair per negotiated asymmetric algorithm
- Ability to use more than one key pair for a negotiated asymmetric algorithm
 - Up to 8 key pairs supported per asymmetric algorithm
- Every key pair could be dedicated for use case, like different key pairs for CHALLENGE and GET_MEASUREMENTS signature generations
- Requester is allowed to associate each key pair with an individual device certificate to enable one or more use cases
 - Multi Key Support enables additional use cases such as certificate provisioning in production or customer environments
 - Improved security posture
- Key pairs are identified by a unique KeyPairID



Generic Certificates Support

- What is a Generic Certificate or Certificate chain?
 - A Certificate or Certificate Chain that could not be qualified as a Device Certificate nor Alias Certificate
- New Feature
 - Generic Certificate model is introduced to support Multiple Asymmetric Keys use cases
 - Generic Certificate Model is the most flexible (or least restrictive) of the certificate models
 - Generic Certificate Model applies to certificates in slots greater than 0.
 - A Device or Alias Certificate is required in slot 0.

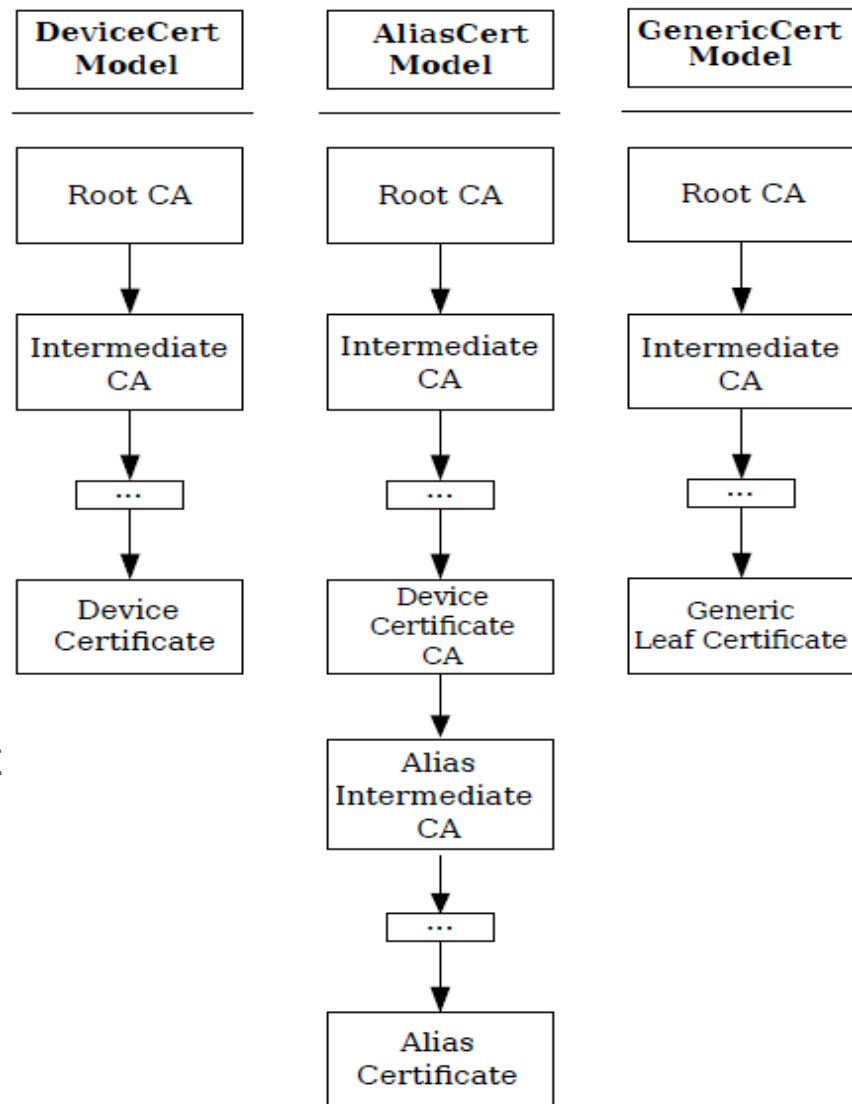



New Measurements

- `NewMeasurementRequested` field is introduced in the request attributes of the GET_MEASUREMENTS request.
 - If Responder has any changes affecting measurements that are requested by Requester but not yet applied (for example, pending changes due to a firmware update), then these new measurement values should be returned instead of current measurements (if requested using the value in the field above)
 - If there are no pending changes, then current measurements are returned regardless of the value in `NewMeasurementRequested` field
- This enables the Requester to prepare as well as to apply policy as per the system



Measurement Extension Log (MEL) and Hash-Extended Measurements (HEM)

- Responder may support reporting of measurements thru an “extend” scheme
 - Initialize HEM = HashSize bytes of 0s
 - For each extend operation, perform HEM = hash(Concatenate(HEM, DataToExtend)) for all data elements to extend
- The MEL is the collection of DataToExtend
 - Could include configuration measurements, firmware measurements, version number, etc.
 - The MEL may be preserved across resets
- An example of such a scheme is the Platform Configuration Register “extend” function in Trusted Platform Modules.
- There is a new MeasurementValueType 0x08 introduced for HEM

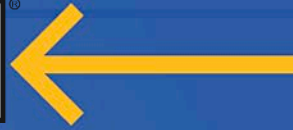

MEL and HEM

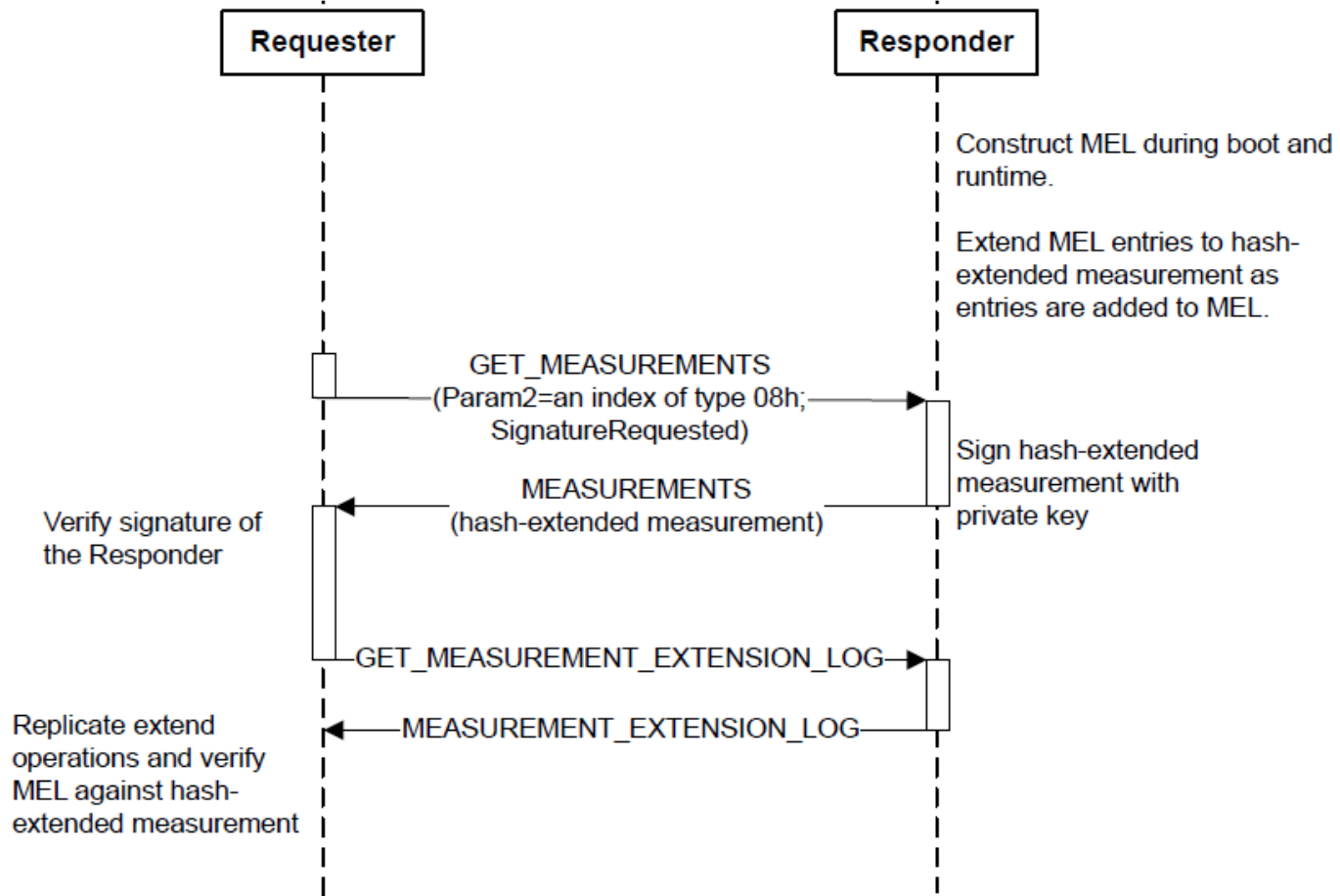



Structured Manifest format for a measurement block

- Data structure that describes the contents of other indices or contains measurements itself.
- Either Free Format or Structured
 - Free Format is implementation specific
 - Structured Format provides a Standards body or vendor-defined header, and manifest data in the format defined by the Standards body or vendor





Endpoint Info

- The GET_ENDPOINT_INFO request message retrieves general information from an endpoint.
 - The SubCode parameter is used to differentiate between operations.
 - The message supports a signature.
- Currently only one Subcode is defined: ***DeviceClassIdentifier***
 - The **DeviceClassIdentifier** response returns information that can be used to identify the class of device for the Responder in question.
 - For instance, DeviceClassIdentifier could contain PCI Vendor ID and Device ID fields.



And Beyond.....

FEATURES UNDER DEVELOPMENT BY THE SPDM WG



SPDM over TCP/IP Binding

- Adds a binding spec (DSP0287) to support SPDM over TCP/IP connections
 - Target is Ethernet-based fabrics and use in conjunction with RDMA
 - Provides standardized way to establish the security of a TCP/IP fabric before opening a memory window
 - Reuses existing SPDM protocol (DSP0274)
- Sample use cases
 - Provisioning certificates from a CA server to a device
 - Using a remote Attester to offload SPDM attestation from the local PA-RoT
 - Allowing an SPDM Requester to retrieve reference measurements
 - Secure data transfer between a device and server that is lighter than HTTP/TLS

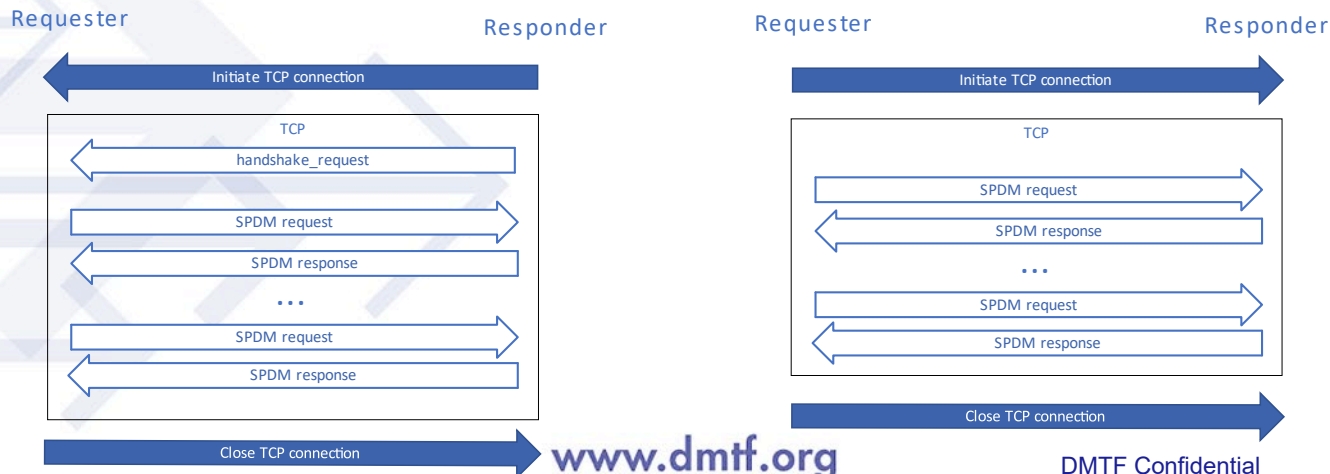



SPDM over Storage Binding

- Adds a binding spec (DSP0286) to support SPDM over storage transports
 - Supports SAS, SATA, and NVMe over fabrics
 - Leverages existing storage commands (IF-SEND and IF-RECV)
 - Reuses existing SPDM protocol (DSP0274)
- Sample use cases
 - Authenticate a drive before using it for data storage
 - Attest the state of a drive
 - Establish a secure session to exchange secrets with a drive

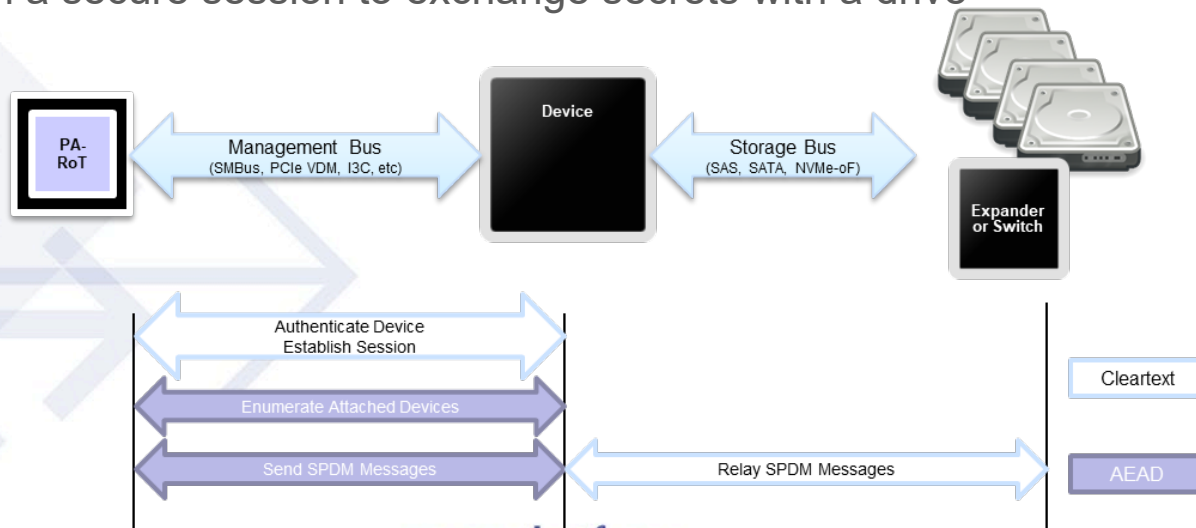

Authorization Specification

- Creates a new specification to enable authorization
 - Provides a mechanism to determine whether the requesting entity has the correct privileges to perform a protected action
- Generalized approach
 - Leverages SPDM Secured Messages
 - Can be used for SPDM, PLDM, vendor-defined messages and more
- Supports multiple sets of privileges
- Scalable to support large numbers of endpoints (data centers)

AuthNonce
 AuthNonce = (User Nonce || Responder Nonce)
 AuthNonce0 = AuthNonce
 AuthNonce1 = AuthNonce0 + 1
 ...
 AuthNonceN = AuthNonce(N-1) + 1

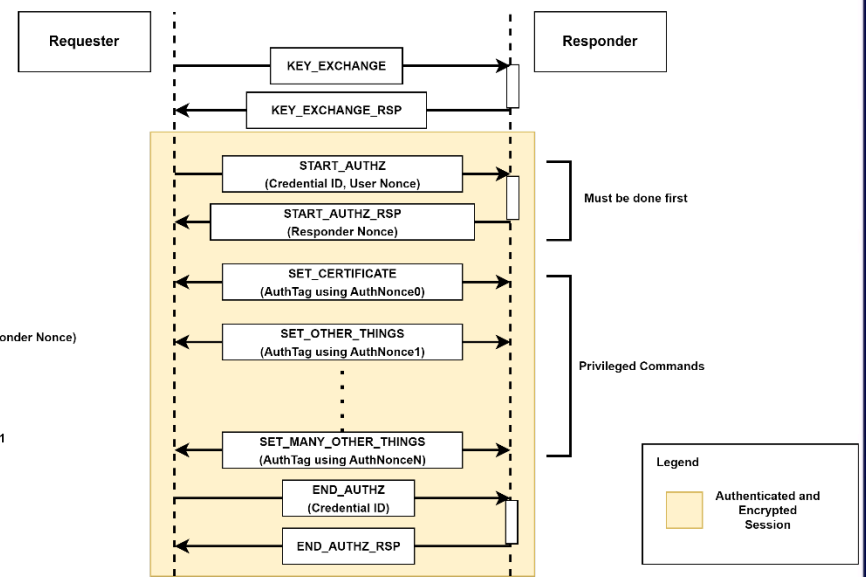



Take Aways

- SPDM protocol is a prominent industry standard for Component and Device Attestation
- Has traction among other industry standard organizations and among component and system vendors
 - DMTF plans to submit the SPDM specification to ISO for ratification
- Use cases and specification work are expanding
- DMTF seeks participation, collaboration and input from the industry



Backup





SPDM over MCTP including Encrypted Messages

Figure 2 — SPDM over MCTP

